

Review of Different Topologies of Multilevel Inverters

¹Rejoice Thomas Paul
¹Department of Electrical Engineering
¹ASIET, Kalady

Abstract

The multilevel inverters are widely used in industries for medium and high voltage applications. This paper presents a study on various topologies of multilevel inverters along with a comparison between these topologies. In this paper circuit configuration, advantage, disadvantage and applications of these topologies are discussed.

Keyword- Cascaded H-Bridge, Current Source Inverters, Diode Clamped, Flying Capacitor, Multilevel Inverters, Voltage Source Inverters

I. INTRODUCTION

The inverters were invented by Toshiba and Samuel Grels Barnes in 1997. Inverters are power electronic circuits which are capable of converting DC voltages to AC voltages. Inverters do not produce any power, they rather use power provided by DC source. The output waveforms are generally sine wave, square wave or quasi square wave. Different types of inverters are given below:

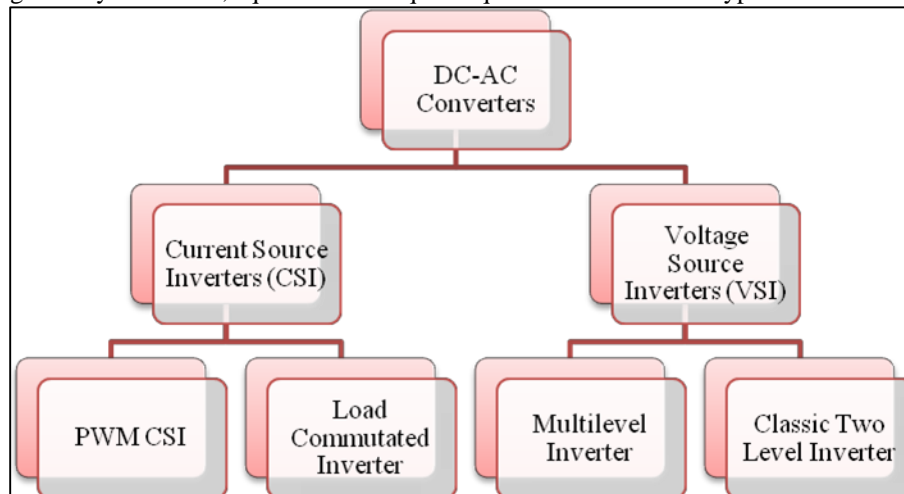

Fig. 1: Different Types of Inverters

From Fig. 1, inverters are majorly classified as current source inverters (CSI) and voltage source inverters (VSI). Though both types of inverters can be used in every application where inverter is used but voltage source inverters are more widely used as compared to current source inverters as they have following advantage over current source inverters [1]:

Power semiconductors with bi-directional voltage blocking capability are required by the current sourced converters. The available high power semiconductors with gate turn-off capability (GTOs, IGBTs) either cannot block reverse voltage at all or can only do it with detrimental effect on other important parameters (e.g., increased conduction losses).

- 1) Practical current source termination of the converter dc terminals by a current charged reactor (inductor) is much lossier than complementary voltage source termination by a voltage-charged capacitor.
- 2) The current-sourced converter requires a voltage source termination at ac terminals, usually in the form of a capacitive filter. The voltage-sourced converter requires a current source termination at the ac terminals that is naturally provided by the leakage inductance of the coupling transformer.
- 3) The voltage source termination (i.e., a large dc capacitor) tends to provide an automatic protection of the power semiconductors against transmission line voltage transients. Current-sourced converters may require additional overvoltage protection or higher voltage rating for the semiconductors.

Hence, VSI are more prevalent in industries. VSI are further classified as two level inverters and multilevel inverters (MLI). Earlier conventional two level inverters were used but these inverters suffered some serious disadvantage. In order to

overcome these disadvantages multilevel inverters became more popular in industries than traditional two level inverters. The advantages of multilevel inverters over two level inverters are given as follows [2][3]:

- 1) Stair Case Waveform in Output: A multilevel converter generates staircase waveform or quasi-square wave in the output. The total harmonic distortion (THD) generated by the staircase waveform is very low as compared to the THD present in the output of traditional two level converters. Along with low THD, the staircase waveform can also reduce dv/dt stresses and as a result the problems of electromagnetic compatibility are also reduced.
- 2) Common Mode (CM) Voltage: The common mode voltages produced by multilevel converters is small and hence, stress on the bearing of the motor connected to a multilevel motor drive is also small. These common mode voltages can be completely eliminated by using advanced modulation strategies like, sinusoidal pulse width modulation (SPWM).
- 3) Input Current: The input current drawn by a multilevel converter has low distortion.
- 4) Switching Frequency: The operation of a multilevel converter is possible for both fundamental switching frequency and high switching frequency PWM. Hence, by operating at lower switching frequency, the switching losses can be reduced and the efficiency of the system can be increased.

Although multilevel inverters have several advantages over traditional two level inverters but they also suffer from some disadvantages [2]:

- 1) Requirement of large number of power semiconductor devices.
- 2) Each switch used in these inverters, require a gate drive circuit which increases the overall cost of the converter, making it expensive.
- 3) Complexity of overall system increases.

Despite the disadvantages suffered by them MLI are more preferred over any other topology due to its more prominent advantages which are listed above.

II. TOPOLOGIES OF MULTILEVEL INVERTERS

In past few years a number of multilevel inverter topologies were introduced in industries but three of these topologies which are famously called classical topologies are more common in industry. These are:

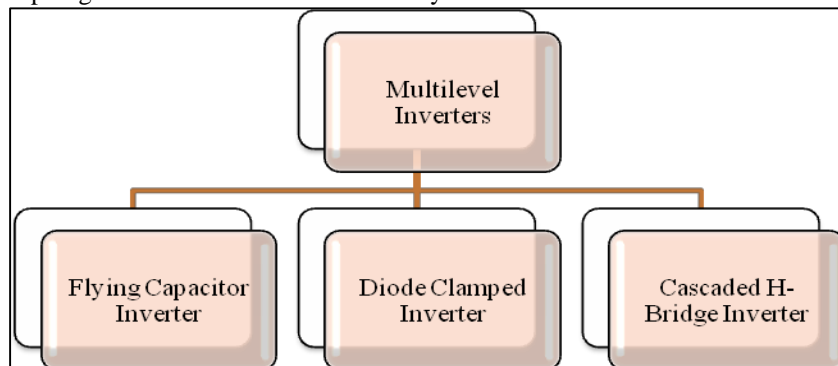

Fig. 2: Topologies of Multilevel Converters

A. Cascaded H-Bridge

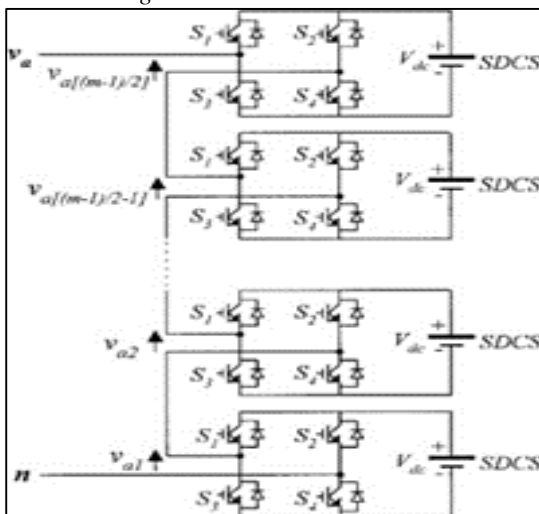

Fig. 3: Single Phase m -level Cascaded H- Bridge Multilevel inverter

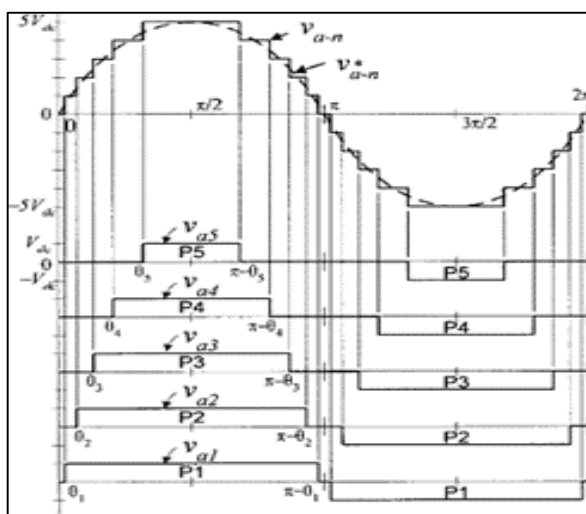

Fig. 4: Output Waveform of Cascaded H-Bridge Multilevel inverter

The basic circuit configuration of cascaded H-Bridge (CHB) topology of MLI is shown in Fig. 3. From this figure it can be observed that CHB consists of several single phase inverter modules which are connected in series and as a result their output gets added up to form a multilevel output. The input side of each module is connected to separate DC sources. Each inverter module can generate three different voltage levels, i.e., $+V_{dc}$, 0 , $-V_{dc}$. These voltage levels are generated by connecting input DC source to output AC side by switching on and off various combinations of switches S1, S2, S3 and S4 [4]. The output waveform of CHB-MLI is shown in Fig. 4.

Advantages of cascaded H-Bridge multilevel converters:

- 1) The total number of output voltage levels is more than twice to that of number of DC sources available.
- 2) The use of separate DC sources provides isolation of between sources of each module.
- 3) Since the outputs of all the modules gets added so voltage rating of individual module is low and hence stress on individual devices also gets reduced.
- 4) The series of H-Bridges makes for modularized layout and packaging. This will enable the manufacturing process to be done more quickly and cheaply.
- 5) The topology due to its modularized structure is highly flexible and hence more convenient to reconfigure in case of occurrence of fault.

Disadvantages of cascaded H-Bridge multilevel converters:

- 1) Separate DC sources are required for each of the separate H-Bridge modules. This limits the application of this converter in products having multiple SDCS already available.
- 2) Though the voltage stress is reduced on each device but the current stress is unequal on individual device. Application areas of cascaded H-Bridge multilevel converters:
- 3) Static VAR generation.
- 4) Interfacing renewable energy sources with grid.
- 5) They can be used in battery based system.
- 6) They are also proposed to be used as main traction drive in electric vehicles where several batteries and ultra-capacitors are being used and are well suited to behave as SDCS.
- 7) Active filters
- 8) Back to Back frequency link systems.

B. Diode Clamped

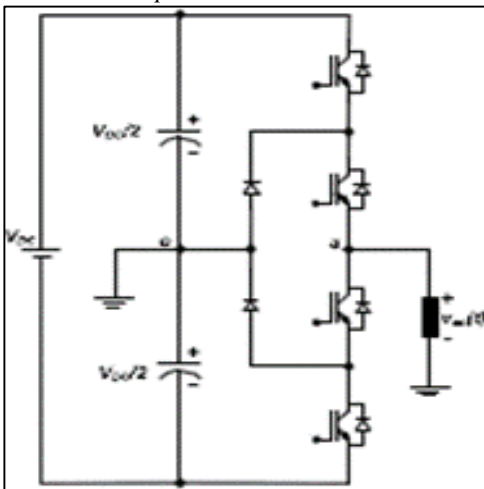

Fig. 5: Single-phase nine-level diode clamped inverter

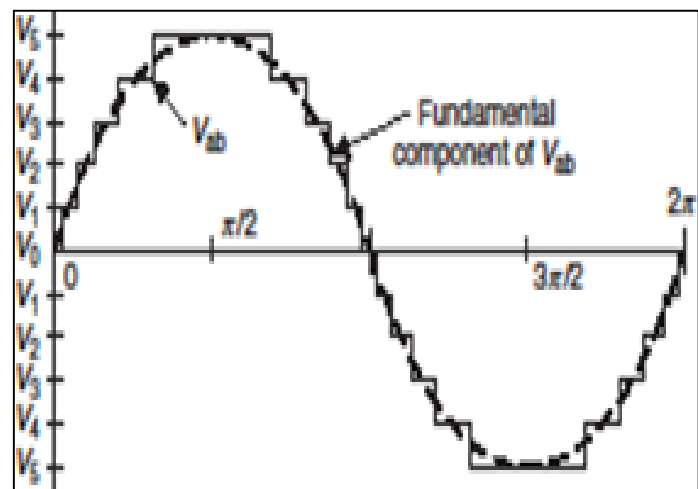

Fig. 6: Output waveform for three-phase six-level diode clamped inverter

This topology of multilevel inverter was proposed by Nabae, Takahashi, and Akagi in 1981. In case of three phase diode clamped converter, each phase shares a common DC bus, which is sub-divided by a number of capacitors to enable the inverter to generate a multiple level staircase waveform. A voltage of V_{dc} is applied across each capacitor and hence the voltage stress across each clamping device is limited to V_{dc} by the clamping diodes.

Advantages of diode clamped multilevel inverter:

- 1) Minimum capacitance requirement of the converter due to sharing of a common bus DC voltage by all three phases. As a result this topology is suitable for high voltage back-to-back interconnections and adjustable speed drives.
- 2) The capacitors can be pre-charged as a group.
- 3) If switching is done at fundamental frequency then the efficiency of inverter is high.
- 4) Less number of devices is needed as compared to cascaded H-Bridge topology.
- 5) These inverters can be used as back to back inverters.

Disadvantages of diode clamped multilevel inverter:

- 1) Flow of real power is difficult for single inverter as intermediate DC levels will tend to discharge and overcharge without precise monitoring and control.
- 2) The number of clamping diodes required is quadratically related to the number of levels, determination of which for high number of output levels can become complex.
- 3) System is not flexible, reconfiguration of inverter cannot be done on occurrence of fault and as a result this topology is not redundant, i.e., if any switch gets damaged, the whole inverter gets offline.

Application areas of diode clamped multilevel inverter:

- 1) Interfacing a high voltage DC transmission line with AC transmission line.
- 2) This topology is well suited for variable speed drive with high power medium voltage motor.
- 3) It can also be used for static VAR compensation applications.
- 4) High voltage system interconnections.

C. Flying Capacitor

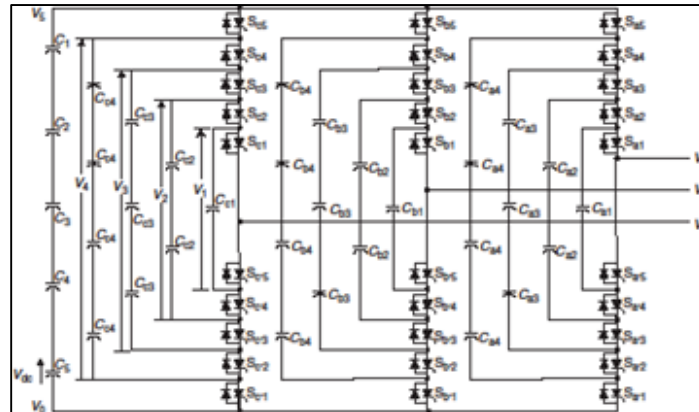

Fig. 7: Three-phase six-level flying capacitor inverter

Flying capacitor inverter was introduced in 1992 by Meynard and Foch. The structure of flying capacitor multilevel inverter is similar to diode clamped multilevel inverter except instead of clamping diodes capacitors are used. In this topology the dc side capacitors have a ladder structure. The voltage across each capacitor differs from that of the next capacitor. The voltage increment between two adjacent capacitor legs gives the size of the voltage steps in the output waveform.

Advantages of flying capacitor multilevel inverter:

- 1) Phase redundancies are available for balancing the voltage levels of the capacitors.
- 2) DC bus sharing is done.
- 3) For same output voltage level lesser number of switching devices is needed.
- 4) The inverter is capable to ride through short duration outages and deep voltage sags due to presence of large number of inverters in its structure.
- 5) Flow of real and reactive power can be controlled.

Disadvantages of flying capacitor multilevel inverter:

- 1) The control is complicated for tracking voltage levels of all capacitors.
- 2) Precharging of all the capacitors to same voltage levels and their start-up is complicated procedure.
- 3) For real power transmission switching utilization and efficiency is poor.
- 4) Large number of capacitors is both more expensive and bulky than clamping diodes which are used in diode clamped configuration.
- 5) The structure is not modularized and bulky and as a result for higher voltage levels packaging is more difficult.

Application areas of flying capacitor multilevel inverter:

- 1) Induction motor control.
- 2) Static VAR generation.
- 3) Applications involving both AC-DC and DC-AC conversion.
- 4) Application where harmonic distortion is high.
- 5) Sinusoidal current rectifiers.

III. COMPARISON BETWEEN CLASSICAL TOPOLOGIES OF MLI

A comparative study between various classical topologies of multilevel inverters is given below:

S.No.	Inverter Topology Characteristics ↓	Cascaded H-Bridge	Diode Clamped	Flying Capacitor
1.	Main switching device	$2(m-1)$	$2(m-1)$	$2(m-1)$

2.	Main Diodes	$2(m-1)$	$2(m-1)$	$2(m-1)$
3.	Clamping Diodes	0	$(m-1)(m-2)$	0
4.	DC bus capacitor	$(m-1)/2$	$(m-1)$	$(m-1)$
5.	Balancing Capacitor	0	0	$(m-1)(m-2)/2$
6.	Redundancy	Redundant	Not Redundant	Redundant
7.	DC Bus Sharing	Separate DC Source	DC Bus Sharing	DC Bus Sharing
8.	Structure	Modular	Not Modular	Not Modular
9.	Flexibility	Flexible	Not Flexible	Not Flexible

Table 1: Comparative study between various classical topologies of multilevel inverter

From Table 1, it can be understood that applications in which modularity and redundancy are important cascaded H-Bridge MLI can be utilized and if cost effectiveness and efficiency are major concern then diode clamped configuration is utilized. If a trade-off between redundancy and cost effectiveness is desired then flying capacitor topology can be selected. Currently, new topologies of MLI which require fewer switches are being introduced like hybrid multilevel inverter with reduced number of switches which are further modified to further reduce the number of switches and reduce overall cost of inverter without affecting working of inverter [5]. The researchers are finding not only ways to reduce the number of switches but also to improve quality of the inverters. Extensive research is being carried out to reduce total harmonic distortion in the inverters. One such inverter with low THD was proposed in [6]. Currently as high as 48-level MLI are being used for providing an output with very low distortion.

IV. CONCLUSION

This paper discussed three most commonly used topologies of multilevel inverters. The circuit configuration, application advantage and disadvantages of these three topologies were also discussed. A brief comparison of CSI and VSI is also given. The paper also highlights the merits of multilevel inverters over traditional two level inverters. A comparative study is also given in this paper which highlights the basic structural and behavioral difference between these topologies of multilevel inverters.

REFERENCES

- [1] L. Gyugyi N. G. Hingorani, Understanding FACTS; Concepts and Technology of Flexible AC Transmission Systems (IEEE Press, New York, United States of America, 2000)
- [2] Tolbert Leon M. Khomfoi Surin, Handbook on Power Electronics (Elsevier, 30 Corporate Drive, Suite 400, Burlington, MA 01803, USA, 2011)
- [3] Abdul Halim Mohamed Yatim Ehsan Najaf, Design and Implementation of a New Multilevel Inverter Topology, IEEE Transactions on Industrial Electronics, 59(11), 2012, 4148 - 4154
- [4] Fang Z. Peng Leon M. Tolbert, Multilevel Converters for Large Electric Drives, Proc. 13th Annual Applied Power Electronics Conference and Exposition, Anaheim, CA, USA, 1998, 530-536
- [5] Pari R., Sivakumar R., Sivaranjani S. Murugesan M., Different Types of Multilevel Inverter Topologies - A Technical Review, International Journal of Advanced Engineering Technology, 7(1), 2016, 149-155
- [6] T.A.Raghavendiran R.Umamageswari, Design and Development of Multi Level Inverter, Proc. International Conference on Engineering Technology and Science-(ICETS'14), Tamilnadu, India, 2014, 1391-1395