

A Review on Application of Dispersion Models for an Industrial Point Source using AerscreenEZ

¹Prasanna Kumar Tiwari ²Kevin Bhikadia ³Prof. Hemali J. Jardosh

³Assistant Professor

^{1,2,3}Department of Civil Engineering

^{1,2,3}SCET, Surat, Gujarat, India

Abstract

Air pollution has been an alarming concern and a threat to our ecosystem since the beginning of the industrial revolution. To combat its ill effects, the first step is to know its concentration and behavior in air. This is done by finding its dispersion in air using different softwares. Such softwares run a predefined algorithm based on various mathematical dispersion models using values given by user. AerscreenEZ is one such software which creates a dispersion scenario of a pollutant using AERMOD atmospheric dispersion model around the source. The basis of AERMOD model is the Gaussian plume dispersion model. Here, various screening softwares based on the Gaussian atmospheric dispersion model are being reviewed with focus on application of AerscreenEZ for point source. The values of stack height, stack diameter, emission concentration, gas emission velocity, stack temperature and the prevailing meteorological conditions are given as input. The output obtained is in a graph form where concentration (y-axis) v/s distance (x-axis) is plotted which indicates the dispersion of the emitted pollutant from the point source in its surrounding.

Keyword- Dispersion, Air Pollution, AerscreenEZ

I. INTRODUCTION

Since the advent of industrial revolution emission of various pollutants in forms of flue gas, process gas are being emitted in atmosphere without considering the self- purification capacity of the atmosphere. Firstly few mathematical models were developed which considered factors such as emission rate, emission concentration, gas- temperature. Some models also incorporated the meteorological parameters for evaluating the dispersion of gases in atmosphere. This proved to be a very tedious and time consuming technique as it involves equating and solving large mathematical problems manually and also possibilities of error were high. So to optimize the time consumption and errors in manual calculations, softwares were developed using dispersion models which proved out to be very much time efficient as well as had minimum possibilities of errors.

The base of any atmospheric dispersion model is always a mathematical algorithm which helps in predicting the impact area as well as the concentration of any specific pollutant in desired areas. Most precise and widely used atmospheric dispersion model for simulation of point source is the Gaussian plume model.

Gaussian air pollutant dispersion equation:

$$C = \frac{Q}{u} \cdot \frac{f}{\sigma_x \sqrt{2\pi}} \cdot \frac{g_1 + g_2 + g_3}{\sigma_z \sqrt{2\pi}}$$

Where:

f = crosswind dispersion parameter.

$$= \exp [-y^2 / (2 \sigma_y^2)]$$

g = vertical dispersion parameter = $y_1 + y_2 + y_3$

g_1 = vertical dispersion with no reflections.

$$= \exp [-(z-H)^2 / (2 \sigma_y^2)]$$

g_2 = vertical dispersion for reflection from the ground.

$$= \exp [-(z+H)^2 / (2 \sigma_y^2)]$$

g_3 = vertical dispersion for reflection from an inversion aloft.

$$= \sum_{n=1}^{\infty} \{ \exp [-(z - H - 2nL)^2 (2 \sigma_z^2)] + \exp [-(z + H + 2nL)^2 (2 \sigma_z^2)] \exp [-(z + H - 2nL)^2 (2 \sigma_z^2)] \exp [-(z - H + 2nL)^2 (2 \sigma_z^2)] \}$$

C = concentration of emissions, in g/m^3 , at any receptor located:

x meters downwind from the emission source point

y meters crosswind from the emission plume centreline

z meters above ground level

Q = source pollutant emission rate, in g/s

u = horizontal wind velocity along the plume centerline, m/s
 H = height of emission plume centerline above ground level, in m
 σ_z = vertical standard deviation of the emission distribution, in m
 σ_y = horizontal standard deviation of the emission distribution, in m
 \exp = the exponential function

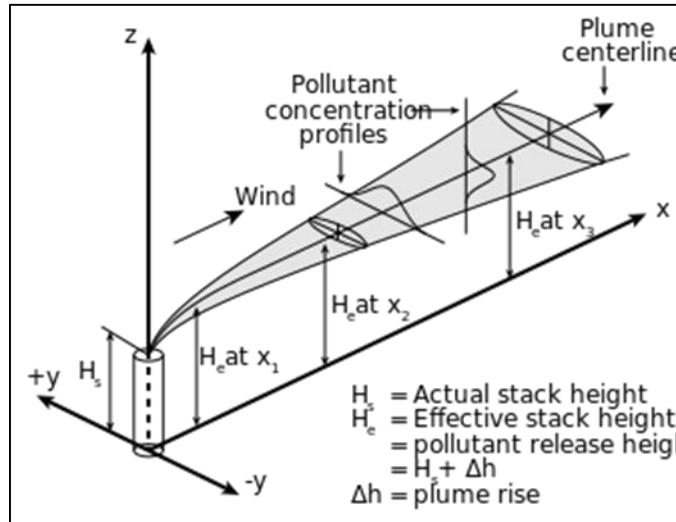

Fig. 1: Gaussian plume model

Modifications in the Gaussian model have given birth to other atmospheric dispersion models which are as listed below with its features and capabilities:

Dispersion Model	Features
AERMOD	It is based on atmospheric boundary layer turbulence structure and scaling concepts, including treatment of multiple ground-level and elevated point, area and volume sources. It handles flat or complex, rural or urban terrain and includes algorithms for building effects and plume penetration of inversions aloft. It uses Gaussian dispersion for stable atmospheric conditions (i.e., low turbulence) and non-Gaussian dispersion for unstable conditions (high turbulence). Algorithms for plume depletion by wet and dry deposition are also included in the model. This model was in development for approximately 14 years before being officially accepted by the U.S. EPA.
CALPUFF	A non-steady-state puff dispersion model that simulates the effects of time- and space-varying meteorological conditions on pollution transport, transformation, and removal. CALPUFF can be applied for long-range transport and for complex terrain.
CALINE3	A steady-state Gaussian dispersion model designed to determine pollution concentrations at receptor locations downwind of highways located in relatively uncomplicated terrain.
CTDMPLUS	A complex terrain dispersion model (CTDM) plus algorithms for unstable situations (i.e., highly turbulent atmospheric conditions). It is a refined point source Gaussian air quality model for use in all stability conditions (i.e., all conditions of atmospheric turbulence) for complex terrain.

Softwares that use the above listed atmospheric dispersion models are:

Dispersion Model	Software
AERMOD	AERMOD, AerscreenEZ
CTDMPLUS	CTSCREEN
ISC3	SCREEN3
PUFF PLUME	TSCREEN

In this paper a review of the evaluation version of AerscreenEZ is done using the sample data set for a point source provided by the software to make a chart of maximum concentration v/s distance.

A. About the Software

AerscreenEZ is a Graphical User Interface (GUI) to AERSCREEN, the screening version of AERMOD dispersion model. The AERSCREEN model contains many components:

- The MAKEMET program which generates a site-specific matrix of meteorological conditions,
- The AERMAP program for processing the terrain information when the simulations are carried out in complex terrain,
- The AERSURFACE program designed to aid in obtaining realistic and reproducible surface characteristic values,
- The AERMOD model for carrying out air dispersion simulations in screening mode.
- "Screening mode" means that the AERMOD model is forced to represent values for the plume centreline, regardless of the source-receptor-wind direction orientation. This mode assures that the model estimates worst-case impacts.

II. METHODOLOGY

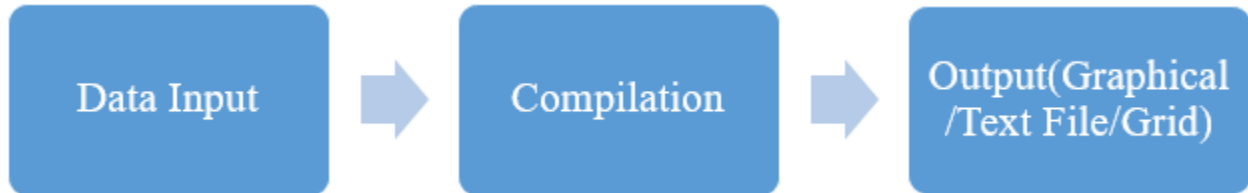

Fig. 2: Methodology

Select the available sample file from available in the software.

Compilation involves the calculation of entered data according to the employed dispersion model within the software.

The output file can be obtained either in text file, graph or a grid form. This output can also be used to determine the effective height & diameter of stack, to make changes in the emission concentration to provide efficient mixing and dispersion of the pollutant in atmosphere for any Industrial point source.

A. AerscreenEZ Home Screen

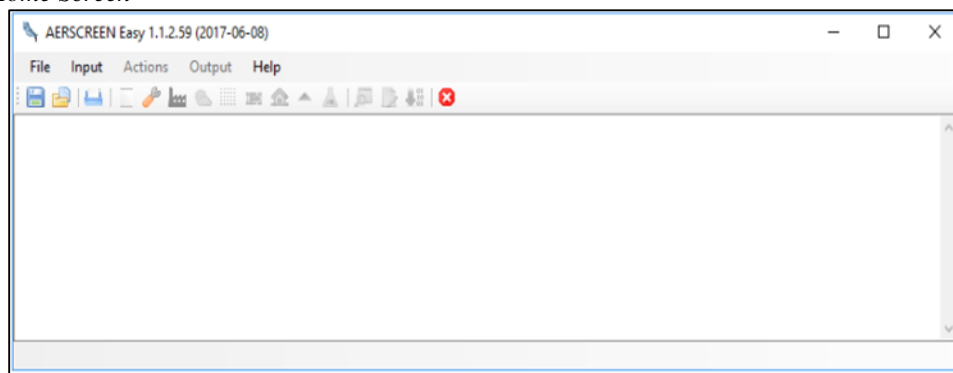

Fig. 3: Home screen

B. Selection Process of Pre-loaded Configuration

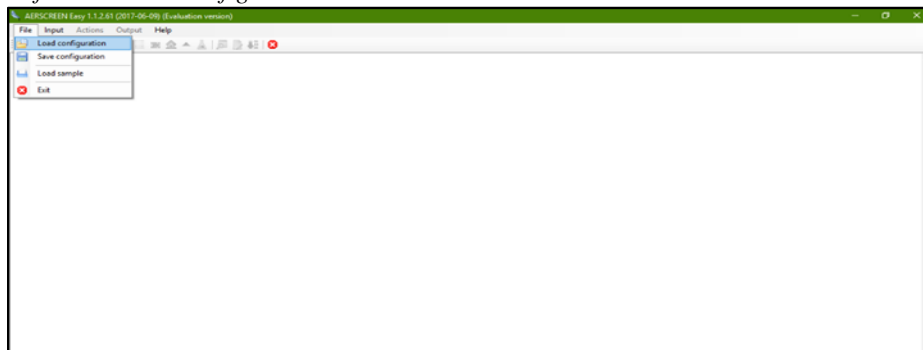

Fig. 4: Configuration Selection

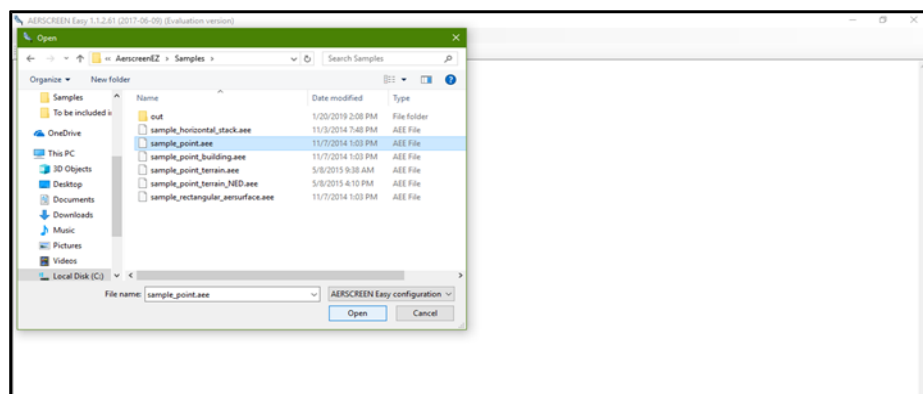

Fig. 5: Input Selection

To obtain output, it is necessary to verify the input using verify tool placed at second last place from left side of the function bar. After successful verification the data can be simulated by using the function on the last place from left hand side. The output can be viewed in any of the three forms available in software i.e. text/ chart/ grid form.

C. Input Data

Sr No.	Operating Parameter	Unit	Source of Emission
1	Stack Height	m	11
2	Stack Diameter	m	0.5
3	Flue Gas Velocity	m/s	5
4	Flue Gas Temperature	K	410
5	Emission Concentration (PM)	g/s	0.120

Table 1: Input Data

III. RESULT

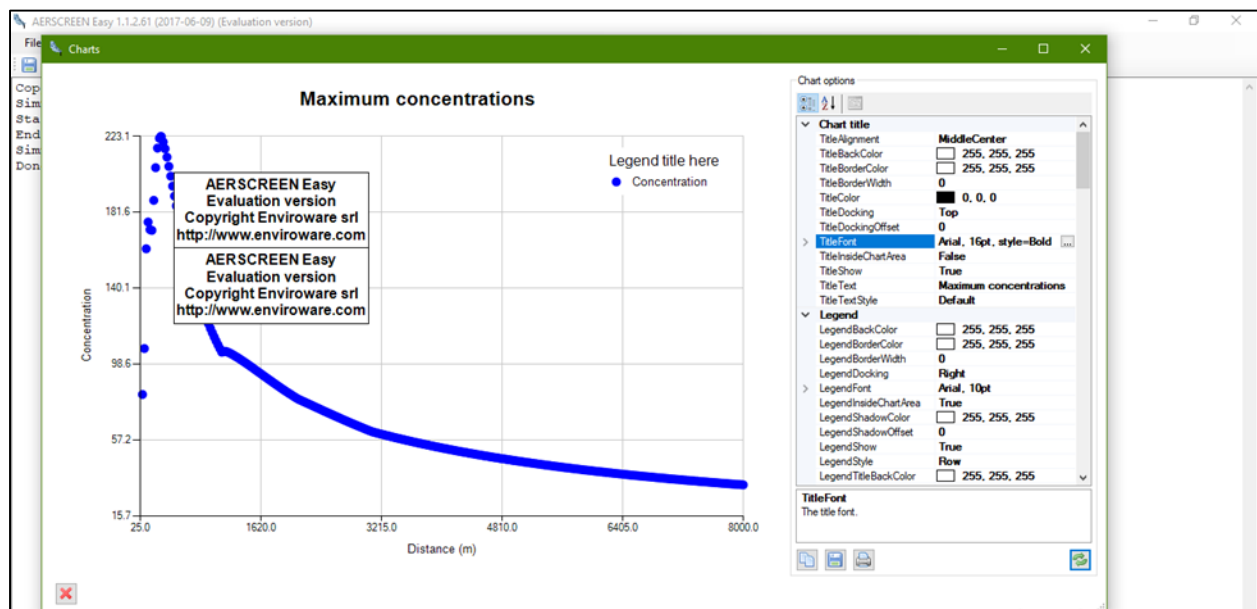

Fig. 6: Maximum Concentration vs. Distance Output Graph

IV. CONCLUSION

The output obtained is a concentration vs distance graph. By analysing the graph it can be concluded that the concentration of a pollutant decreases as the distance from the plume increases. There is a steady decline in the graph as seen in the figure 6. This displays the concentration of a pollutant at different distances. The metrological data can also be added to the software, in this paper a sample file is considered. It can therefore be concluded that AerscreenEZ is an easy to use and a reliable software for dispersion modelling.

REFERENCES

- [1] Mohammad Hashem Askariyeh, Sri Harsha Kota, Suriya Vallamsundar, Josias Zietsman, Qi Ying, 2017. AERMOD for near-road pollutant dispersion: Evaluation of model performance with different emission source representations and low wind options. *Transport and Environment*, 57, 392–402. doi:10.1016/j.trd.2017.10.008
- [2] F. Mataracchiera, C. Manes, R.P. Beaven, T.C.Rees-White, F. Boano, J. Mønster, C.Scheutz, 2018. AERMOD as a Gaussian dispersion model for planning tracer gas dispersion tests for landfill methane emission quantification. *Waste Management*. doi:10.1016/j.wasman.2018.02.007
- [3] Ondřej Sáňka, Lisa Melymuk, Pavel Čupr, Alice Dvorská, Jana Klánová, 2014. Dispersion modeling of selected PAHs in urban air: A new approach combining dispersion model with GIS and passive air sampling. *Atmospheric Environment*, 96, 88–95. doi:10.1016/j.atmosenv.2014.07.002
- [4] Dmitry Tartakovskiy, Eli Stern, David M. Broday, 2016. Indirect estimation of emission factors for phosphate surface mining using air dispersion modeling. *Science of the Total Environment*, 556, 179–188. doi:10.1016/j.scitotenv.2016.02.207

- [5] Milando, C. W., & Batterman, S. A. (2018). Operational evaluation of the RLINE dispersion model for studies of traffic-related air pollutants. *Atmospheric Environment*, 182, 213–224. doi:10.1016/j.atmosenv.2018.03.030
- [6] Liu, Y., Li, H., Sun, S., & Fang, S. (2017). Enhanced air dispersion modelling at a typical Chinese nuclear power plant site: Coupling RIMPUFF with two advanced diagnostic wind models. *Journal of Environmental Radioactivity*, 175-176, 94–104. doi:10.1016/j.jenvrad.2017.04.016
- [7] Heist, D., Isakov, V., Perry, S., Snyder, M., Venkatram, A., Hood, C., Owen, R. C. (2013). Estimating near-road pollutant dispersion: A model inter-comparison. *Transportation Research Part D: Transport and Environment*, 25, 93–105. doi:10.1016/j.trd.2013.09.003
- [8] Rees-White, T. C., Mønster, J., Beaven, R. P., & Scheutz, C. (2018). Measuring methane emissions from a UK landfill using the tracer dispersion method and the influence of operational and environmental factors. *Waste Management*. doi:10.1016/j.wasman.2018.03.023
- [9] <https://www.enviroware.com/portfolio/aerscreenez/>
- [10] https://www.enviroware.com/products/AerscreenEasy_UserGuide.pdf