

# Reduce the Possibility of Short Circuit in Infant Incubators using Peltier Elements and Fault Alert using Mobile Communication

<sup>1</sup>Sangeetha Priya. A <sup>2</sup>Thenmozhi. M <sup>3</sup>Pandeeswari M <sup>4</sup>Devi Priyanka. R <sup>5</sup>Pounraj K  
<sup>1,2,3,4</sup>UG Scholar <sup>5</sup>Professor (Dean)

<sup>1,2,3,4,5</sup>Department of Electrical and Electronics Engineering  
<sup>1,2,3,4,5</sup>SBM College of Engg & Tech, Dindigul, India

## Abstract

This paper is about the concept of baby incubator. Incubator is used for the premature baby to maintain the baby temperature. The temperature production is done by tellurium. Peltier elements is controlled by microcontroller and current direction is controlled by relay. If the heat is increased the direction of the relay is turned on the bismuth. Bismuth cooled the incubator and also fan also connected to cool the incubator. Microcontroller give the signal to the buzzer and at the critical condition, buzzer is on and critical alert is send to the mobile via GSM. At the wet condition, the conductive probe is sense the moisture and the alarm is turned on.

**Keyword-** Peltier Elements, Telurium, Bismuth, Conductive Probe, GSM Modem

## I. INTRODUCTION

Many of the babies are died by the careless mistakes of doctors, equipment failure and the short circuit accidents. This accidents did not get the so much of considerations by the people. As we are engineers, we concern that our project will turn to the solution for the real time problem. So we are considered the short circuit problem in infant incubators. i.e.) to reduce the possibility of short circuit in incubators by using Peltier elements. Peltier elements are tellurium and bismuth. That can control the temperature and if temperature has been increased, bismuth cool out the incubator. This is our aim to decrease the infant deaths.

## II. DESIGN OF INCUBATOR MODEL

### A. Components

- Keys - Pushed on Keys
- Temperature sensor - LM35
- ADC - 0804
- LCD Display - HD44780
- Relay - 12 V relay
- High amps DC source - SMPS 5amps DC source
- Peltier Element - Tellurium, Bismuth
- MAX 232 - RS 232 implemented chip
- Microcontroller - 89C51
- Microcontroller - 89C21

### B. Block Diagram

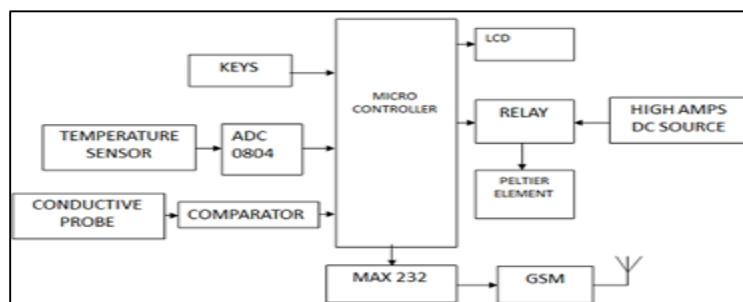

Fig. 1: Block diagram of Temperature Control and Security System

Here low power, high-performance CMOS 8bit microprocessor with Flash Programmable and Erasable read only memory is being used. The output of signal conditioning is in analog form. But microprocessor requires input in digital form, hence analog to digital converter is used.

The relay driver is connected to the Peltier element to control the current direction. The heat is produced via tellurium and the cooling is produced via bismuth. If the heat is increased the relay is turned on to cool the circuit. The cooling is increases the relay is driver turned on and the warmth is produced.

Keypad gives set point for temperature sensor, using reset key, enter, increment & decrement using increment button a set point is incremented.

Output of microcontroller is sufficient to drive the buzzer directly

Microcontroller, temperature sensor, ADC requires +5Volts supply whereas +12 Volts is used to drive the relay.

The conductive probe is connected with the comparator, it compares the voltage value, if it is deviated the alarm is turned on.

The microcontroller 89C21 is connected to control the communication signal in the sim. This control is only with 500 meters.

### III. IMPLEMENTATION

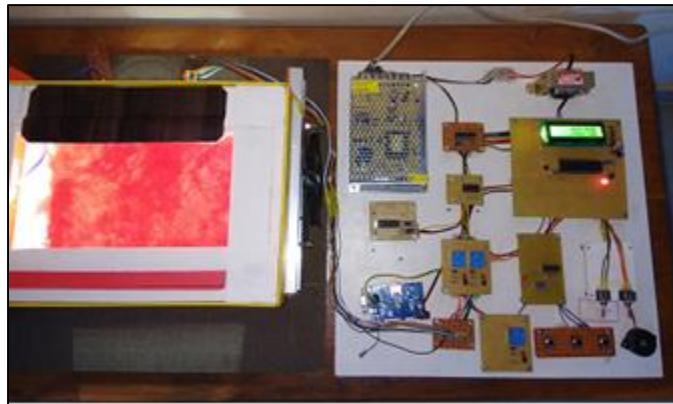

Fig. 2: Peltier element and GSM based infant incubator

### IV. PELTIER EFFECT PRINCIPLE

The Peltier effect is a temperature difference created by applying a voltage between two electrodes connected to a sample of semiconductor material. Thermal energy flows in the direction of the charge carrier.

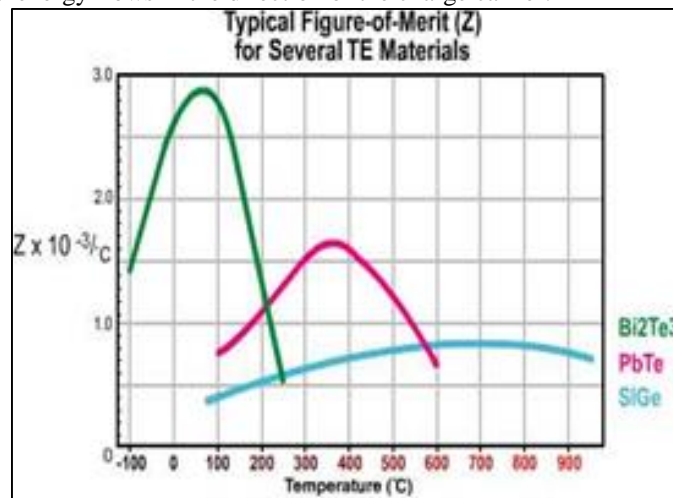

Fig. 3: Typical fig of merit (Z)

### V. BISMUTH TELLURIDE MATERIAL

Crystalline Bismuth Telluride material has several characteristics that merit discussion. Due to the crystal structure, Bi<sub>2</sub>Te<sub>3</sub> is highly anisotropic in nature. This results in the material's electrical resistivity being approximately four times greater parallel to the axis of crystal growth (C-axis) than in the perpendicular orientation. In addition, thermal conductivity is about two time's greater parallel to the C-axis than in the perpendicular direction. Since the anisotropic behaviour of resistivity is greater than that of thermal conductivity, the maximum performance or Figure-of-Merit occurs in the parallel orientation. Because of this

anisotropy, thermoelectric elements must be assembled into a cooling module so that the crystal growth axis is parallel to the length or height of each element and, therefore, perpendicular to the ceramic substrates.

There is one other interesting characteristic of Bismuth Telluride that also is related to the material's crystal structure.  $\text{Bi}_2\text{Te}_3$  crystals are made up of hexagonal layers of similar atoms.

While layers of Bismuth and Tellurium are held together by strong covalent bonds, weak van der Waals bonds link the adjoining  $[\text{Te}^1]$  layers. As a result, crystalline Bismuth Telluride cleaves readily along these  $[\text{Te}^1][\text{Te}^1]$  layers, with the behaviour being very similar to that of Mica sheets. Fortunately, the cleavage planes generally run parallel to the C-axis and the material is quite strong when assembled into a thermoelectric cooling module.

Bismuth Telluride material, when produced by directional crystallization from a melt, typically is fabricated in ingot or boule form and then sliced into wafers of various thicknesses. After the wafer's surfaces have been properly prepared, the wafer is then diced into blocks that may be assembled into thermoelectric cooling modules. The blocks of Bismuth Telluride material, which usually are called elements or dice, also may be manufactured by a pressed powder metallurgy process.

## VI. THERMOELECTRIC COOLING MODULE

A practical thermoelectric cooler consists of two or more elements of semiconductor material that are connected electrically in series and thermally in parallel. These thermoelectric elements and their electrical interconnects typically are mounted between two ceramic substrates. The substrates serve to hold the overall structure together mechanically and to insulate the individual elements electrically from one another and from external mounting surfaces. After integrating the various component parts into a module, thermoelectric modules ranging in size from approximately 2.5-50 mm (0.1 to 2.0 inches) square and 2.5-5mm (0.1 to 0.2 inches) in height may be constructed.

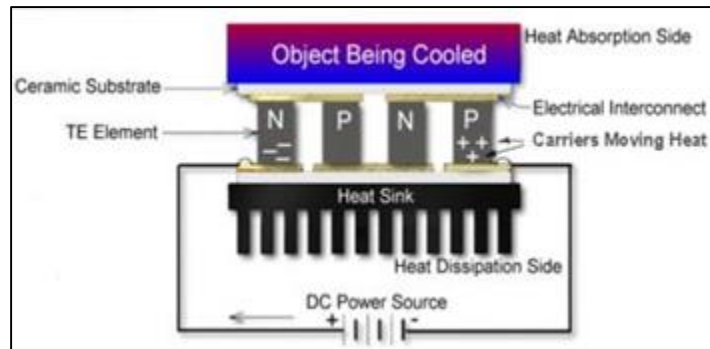

Both N-type and P-type Bismuth Telluride thermoelectric materials are used in a incubator. This arrangement causes heat to move through the cooler in one direction only while the electrical current moves back and forth alternately between the top and bottom substrates through each N and P element. N-type material is doped so that it will have an excess of electrons (more electrons than needed to complete a perfect molecular lattice structure) and P-type material is doped so that it will have a deficiency of electrons (fewer electrons than are necessary to complete a perfect lattice structure). The extra electrons in the N material and the "holes" resulting from the deficiency of electrons in the P material are the carriers which move the heat energy through the thermoelectric material. Most thermoelectric cooling modules are fabricated with an equal number of N-type and P-type elements where one N and P element pair form a thermoelectric "couple."

Heat flux (heat actively pumped through the thermoelectric module) is proportional to the magnitude of the applied DC electric current. By varying the input current from zero to maximum, it is possible to adjust and control the heat flow and temperature.



Fig. 4: Manual mode temperature

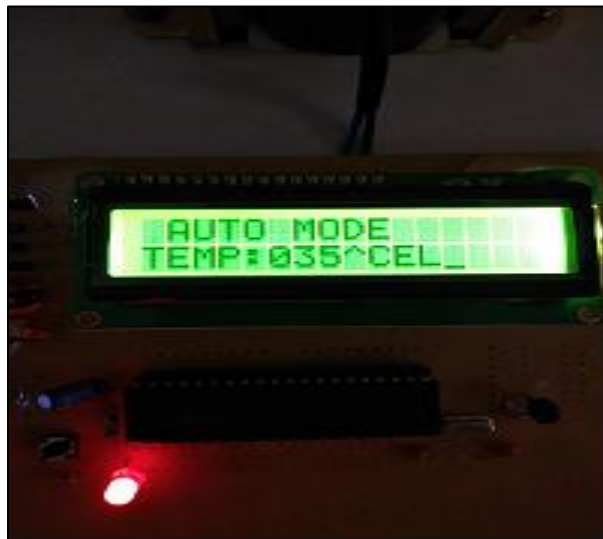

Fig. 5: Auto mode temperature



Fig. 6: critical message alert from GSM.

*A. Advantages*

- The possibility of short circuit has been decreased while using the Peltier element
- Power consumption is low.
- Cost is low.
- Accuracy is high by using temperature sensor and micro controller.

*B. Disadvantages*

- By using the Peltier elements the skin irritation is coming to the baby.
- In case of power failure this project will not run, will require a supply backup.
- The incubator being an enclosed apparatus, the switch to backup supply has to be fast or else could lead to suffocation.

## VII. CONCLUSION

In this paper we concentrate to reduce the infant death due to short circuit accidents. So our project is reduce the infant deaths and increase the secure system of the incubator. By using Peltier elements to the replacement of heating coil is give the best result. Bismuth is cooling element and the temperature control is gain by this element efficiently.

## REFERENCES

- [1] Patil, R. P., Prof., Suryawanshi, P., Pawar, A., & Pawar, A. (2017). THERMOELECTRIC REFRIGERATION USING PELTIER EFFECT. INTERNATIONAL JOURNAL OF ENGINEERING SCIENCES & RESEARCH TECHNOLOGY, 6(5), 614-618. doi:10.5281/zenodo.800636

- [2] Titov, O. Yu; Gonzalez de la Cruz, G; "New physical point of view on the Peltier effect," Thermoelectric, 1997. Proceedings ICT 1997.
- [3] Solar Refrigeration System by using Peltier Module. Oshin Dhage, Rupali Gaikwad, Pooja Nagrale, Pooja Bomratwar, Anuradha Mogare Datta meghe institute of engg. Technology & research, Wardha (Electrical engg.)
- [4] [www.memmert.com](http://www.memmert.com)
- [5] [www.atmosafe.net](http://www.atmosafe.net)